

**SUPPLEMENTAL INSTALLATION INSTRUCTIONS**

FIXTURE TYPE \_\_\_\_\_

**LG-WWD-44, R-WWD-44 & RP-WWD-44 FIXTURE**

P/C **510553-2000**

PG. 1 OF 1

DO NOT MODIFY OR ALTER THIS PRODUCT IN ANY WAY, OR INSTALL IN ANY FASHION WHICH IS CONTRARY TO THE INSTRUCTIONS CONTAINED HEREIN. IF YOU HAVE ANY QUESTIONS REGARDING THIS PRODUCT OR THE INSTALLATION OF IT, PLEASE CALL LITECONTROL ENGINEERING AT 781-294-0100.

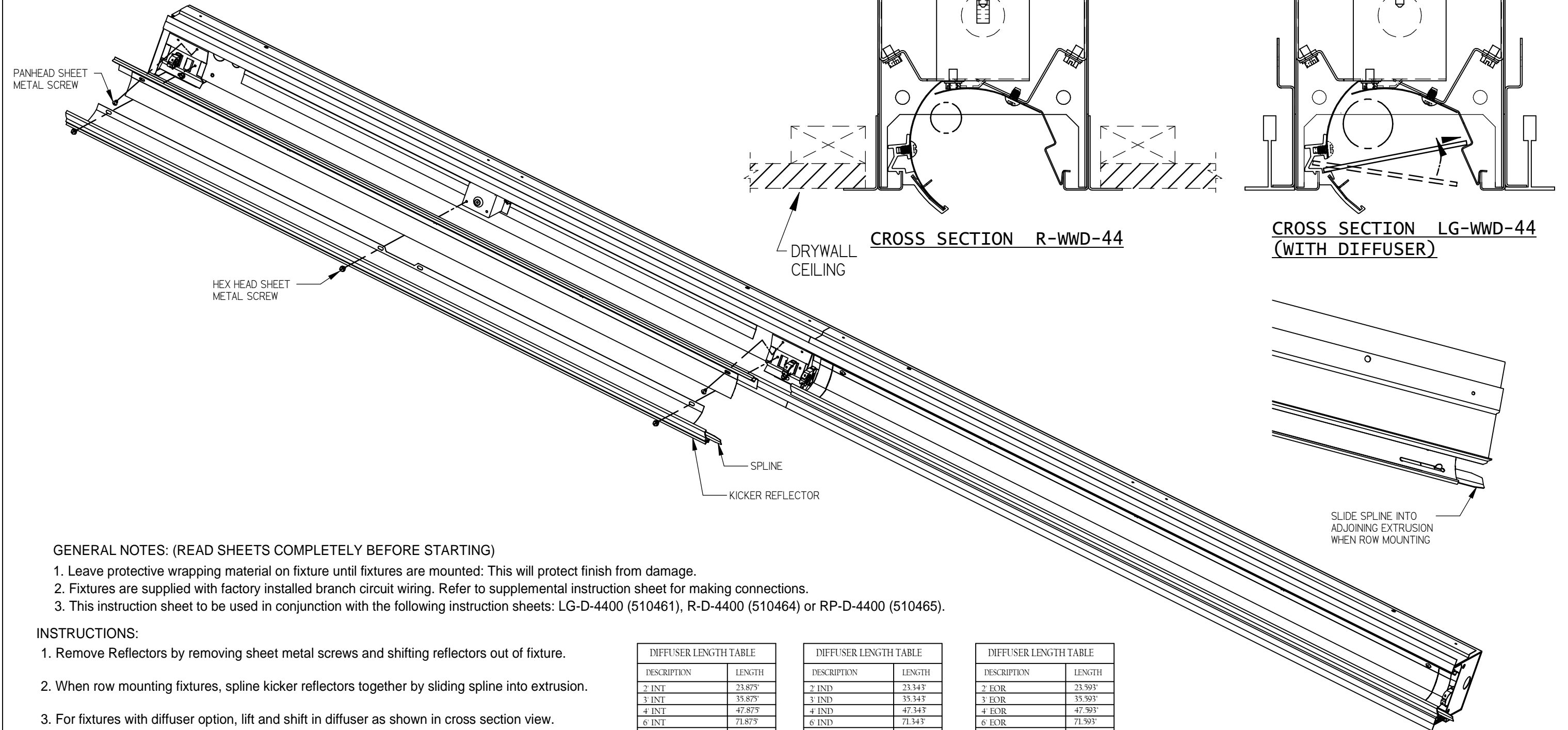

**GENERAL NOTES: (READ SHEETS COMPLETELY BEFORE STARTING)**

1. Leave protective wrapping material on fixture until fixtures are mounted: This will protect finish from damage.
2. Fixtures are supplied with factory installed branch circuit wiring. Refer to supplemental instruction sheet for making connections.
3. This instruction sheet to be used in conjunction with the following instruction sheets: LG-D-4400 (510461), R-D-4400 (510464) or RP-D-4400 (510465).

**INSTRUCTIONS:**

1. Remove Reflectors by removing sheet metal screws and shifting reflectors out of fixture.
2. When row mounting fixtures, spline kicker reflectors together by sliding spline into extrusion.
3. For fixtures with diffuser option, lift and shift in diffuser as shown in cross section view.

DIFFUSER LENGTH TABLE	
DESCRIPTION	LENGTH
2' INT	23.875"
3' INT	35.875"
4' INT	47.875"
6' INT	71.875"
8' INT	95.875"

DIFFUSER LENGTH TABLE	
DESCRIPTION	LENGTH
2' IND	23.343"
3' IND	35.343"
4' IND	47.343"
6' IND	71.343"
8' IND	95.343"

DIFFUSER LENGTH TABLE	
DESCRIPTION	LENGTH
2' FOR	23.593"
3' FOR	35.593"
4' FOR	47.593"
6' FOR	71.593"
8' FOR	95.593"