

INSTALLATION INSTRUCTIONS

FIXTURE TYPE _____

W-AI-3400
W-ASD-3400
W-AID-3400

P/C **510380-6000**

DATE: 9-4-09

PG. 1 OF 2

DO NOT MODIFY OR ALTER THIS PRODUCT IN ANY WAY, OR INSTALL IN ANY FASHION WHICH IS CONTRARY TO THE INSTRUCTIONS CONTAINED HEREIN. IF YOU HAVE ANY QUESTIONS REGARDING THIS PRODUCT OR THE INSTALLATION OF IT, PLEASE CALL LITECONTROL ENGINEERING AT 781-294-0100.

GENERAL NOTES:

1. End Caps and Fascia's are shipped separately
2. Fascia's may be rotated into one of 3 positions as shown in End Views.
3. Installer to provide, 2 x 4 outlet box with cover and #10 wall anchors, washers and screws for mounting fixtures.
4. Fixtures are supplied with factory installed branch circuit wiring, refer to supplemental instructions for making wiring connections.

INSTRUCTIONS:

1. Chalk a level line along mounting wall as shown in Back Views.
2. Remove foam wrapping from fixture and lift off ballast cover by loosening 2 sheetmetal screws.
Note: LCD is shipped unattached.
3. Fixture is supplied with two 7/8" or 2" dia. KO's for bringing wire feed into back of housing.
4. **MOUNTING INDIVIDUAL FIXTURES:**
 - A) Align wire feed ko in back of housing over center of outlet box and secure fixture to wall with a minimum of (2) #10 anchors thru T-slots as shown on page 2. Level Housing before tightening anchor screws. To prevent housing damage, do not overtighten screws. Rubber Bumpers have been factory installed inline with T-slots, extra bumpers are shipped with fixture and should be installed inline at each additional anchor location. Secure housing from moving by inserting another anchor screw thru an unused Bumper Hole into wall.
 - B) Bring electrical feed into fixture wireway and make connections.
 - C) Replace Ballast cover.
5. **MOUNTING ROWS OF FIXTURES:**
 - A) Locate and mount the first fixture in row per Steps 4A and 4B above.
 - B) Place the next fixture in row up against end of first fixture and mount to wall. Level fixture so that the end headers are aligned at the joint and bolt together thru keyed 5/8" hole with one # 10-24 x 1/2" long machine screw and nut provided. See Row Joint View on page 2.
 - C) Insert branch circuit wiring thru 5/8" feed hole and make connections in fixture wireway. Repeat this step for each additional fixture in row and replace Ballast Covers.
6. Install lamps [supplied by others]. *NOTE:* T5 lamps are inserted into sockets and rotated 90 degrees.

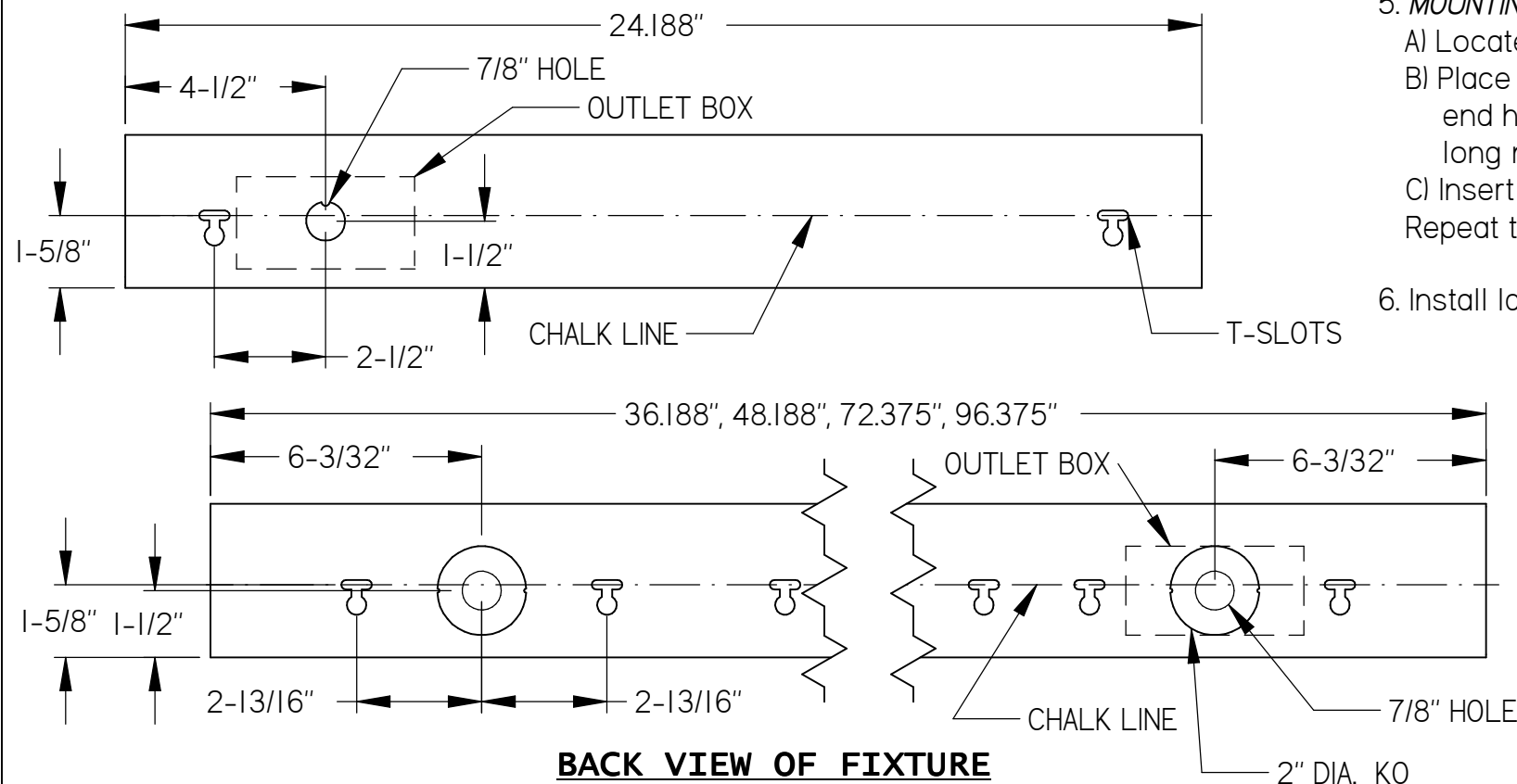
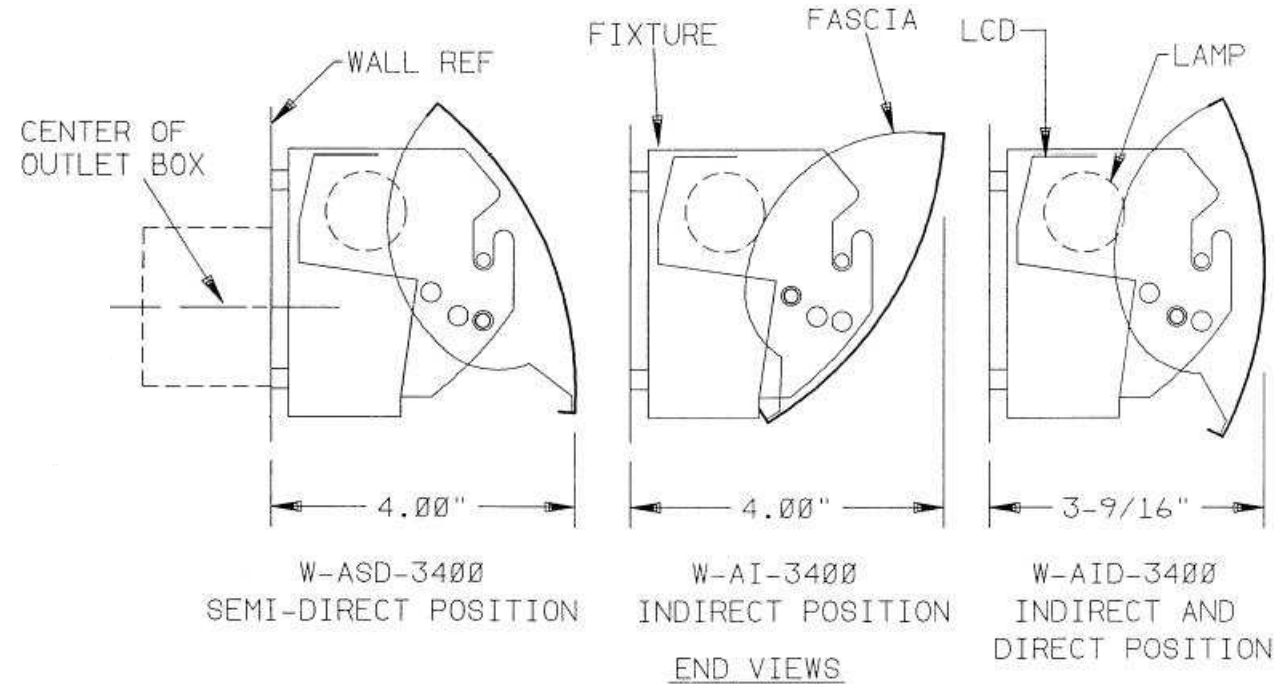

7. Attach LCD's by inserting lances into Ballast Cover tabs as shown on page 2.
8. Mount Fascia's to fixtures per Installation Instructions 510382. Refer to catalog number for correct position required.
9. Attach one End Cap to both ends of an individually mounted fixture or both ends of a row of fixtures per installation instructions 510383.

INSTALLATION INSTRUCTIONS

PART NO. **510380-6000**

FIXTURE TYPE _____

DATE: 9-4-09

FIXTURE W-AI-3400
W-ASD-3400
W-AID-3400

Pg. 2 OF 2

DO NOT MODIFY OR ALTER THIS PRODUCT IN ANY WAY, OR INSTALL IN ANY FASHION WHICH IS CONTRARY TO THE INSTRUCTIONS CONTAINED HEREIN. IF YOU HAVE ANY QUESTIONS REGARDING THIS PRODUCT OR THE INSTALLATION OF IT, PLEASE CALL LITECONTROL ENGINEERING AT 781-294-0100.

INSTRUCTIONS con't:

