

The SAE 7700 is a Cradle to Cradle Certified<sup>CM</sup> fixture in the Simple-Affordable-Efficient family from Litecontrol. The fixture's open steel baffle is over 90% efficient with an indirect-direct light distribution that provides comfortable ambient room lighting and high task footcandle levels. This guide documents the performance of the SAE 7700 pendant fixture when used in typical classroom configurations. It also shows how the innovative Litecontrol CS/av audio-visual control solution enables flexibility in the classroom for today's multi-modal teaching styles. The information provided should help architects, engineers, school planners and contractors to assess the performance of the SAE 7700 and CS/av system in classroom applications.

**This guide includes four common classroom configurations, with calculated results for the SAE 7700 fixtures and the CS/av control solution.**

Calculations are shown for a three-lamp fixture operated in each of four lighting modes:

- General mode: two outer lamps ON in all fixtures throughout the entire room. This mode is typical of a 2-lamp system, with or without CS/av controls.
- AV mode: one center lamp ON with lamps OFF in the fixtures closest to the AV wall. This mode is consistent with the LEED for Schools and CHPS definition.
- All ON – Low mode: one center lamp ON in all fixtures throughout the room.
- Front OFF – High mode: two outer lamps ON with lamps OFF in the fixtures closest to the AV wall.

The summary tables for the example applications show:

- The lighting mode as defined above.
- The number of lamps ON in each fixture that is energized in that mode.
- The average horizontal illuminance level in footcandles (fc) at the desktop height.
- The average vertical illuminance level in footcandles on the whiteboard surface.
- The uniformity ratio between the average and the minimum footcandle level at the desktop height.
- The uniformity ratio between the maximum and the minimum footcandle level at the desktop height.
- The power density in Watts per square foot.
- The ability of the system to meet LEED for Schools and CHPS Classroom Lighting criteria, where applicable.



**LEED for Schools Classroom Lighting Criteria:**

- Provide a lighting system that operates in two modes: general and AV.
- General mode must provide average light level at desk of 35-50 footcandles.
- AV mode must provide average light level at desk of 10-20 footcandles.
- AV mode must provide no more than 7 vertical footcandles on the projection screen.

**CHPS Classroom Lighting Criteria:**

- Use multi-scene lighting systems with general and AV modes.
- General mode must provide average light level at desk of 35-50 footcandles.
- AV mode must provide average light level at desk of 10-20 footcandles.
- AV mode must provide no more than 7 vertical footcandles on the projection screen.
- Use photocontrols to automatically turn off or dim the electric lights when daylighting is available.

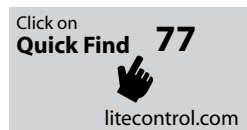

### 24' x 30' Classroom with 2-24' Fixture Rows

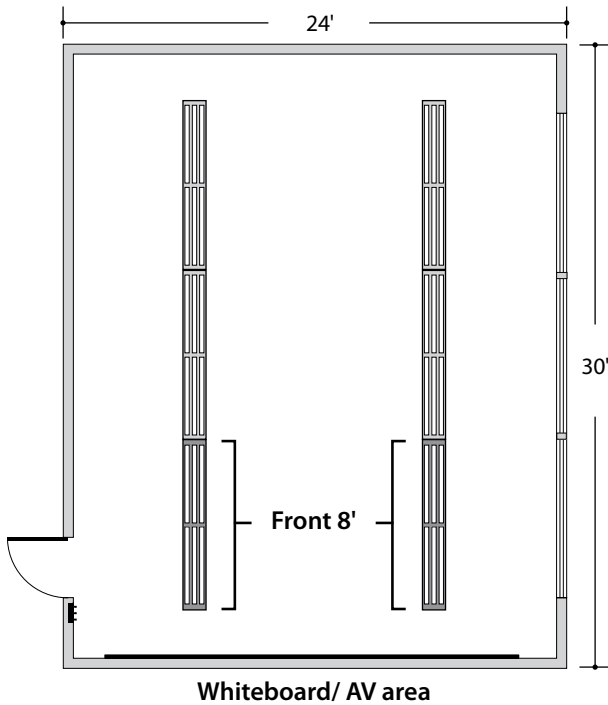

The diagram at left depicts a 24' X 30' classroom with two 24' rows of **SAE 7700** fixtures, which are perpendicular to the AV presentation/ whiteboard wall. Using the **CS/av** control solution, the fixtures in each of the rows can either have one or two lamps turned on depending on the lighting requirements of the students. The front 8' of the fixtures in each of the rows are switched off in AV mode to minimize light in the projection area.

Mode*	# of lamps	Ave fc	Ave fc on Whiteboard	Ave/Min	Max/Min	W/ft <sup>2</sup>	LEED	CHPS
General	2	50	24	2.5	3.7	1.0	✓	✓
AV	1	16	3	8	18.5	0.4	✓	✓
All ON - Low	1	24	10	2.9	4.8	0.6	N/A	N/A
Front OFF - High	2	33	8	6.5	13.2	0.6	N/A	N/A

### 30' x 30' Classroom with 3-24' Fixture Rows

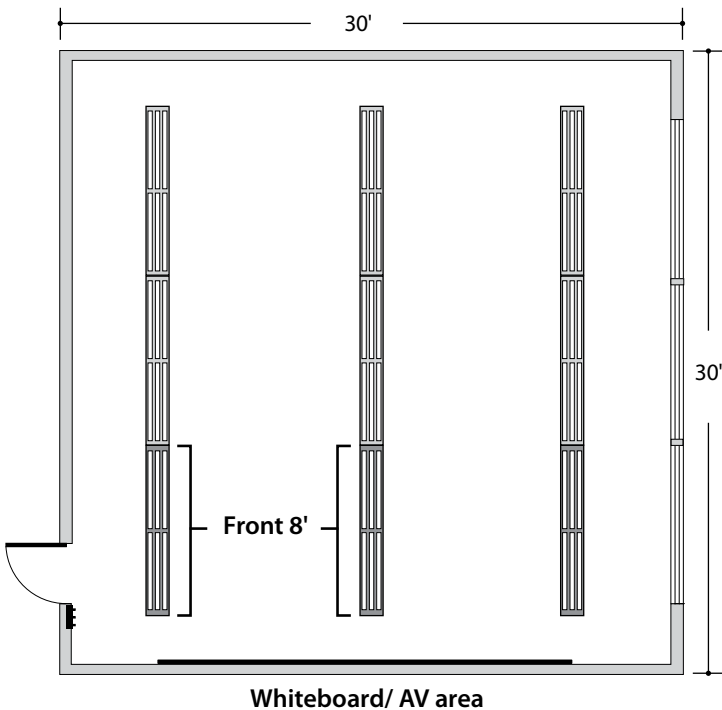

The diagram at left depicts a 30' X 30' classroom with three 24' rows of **SAE 7700** fixtures, which are perpendicular to the AV presentation/ whiteboard wall. Using the **CS/av** control solution, the fixtures in each of the rows can either have one or two lamps turned on depending on the lighting requirements of the students. The front 8' of the fixtures in each of the rows are switched off in AV mode to minimize light in the projection area.

Mode*	# of lamps	Ave fc	Ave fc on Whiteboard	Ave/Min	Max/Min	W/ft <sup>2</sup>	LEED	CHPS
General	2	61	29	2.4	3.5	1.2	✓	✓
AV	1	19	4	7.8	17.0	0.5	✓	✓
All ON - Low	1	29	12	2.7	4.3	0.8	N/A	N/A
Front OFF - High	2	40	10	6.3	12.3	0.8	N/A	N/A

#### Assumptions/Givens for Examples:

Calculated values using AGI 32 software  
 LLF = 0.75, Surface Reflectances = 80/50/20, Wall Height = 9.5',  
 Fixture Row Spacing = 12' OC,  
 Input Power for 2-lamp Configuration = 58 watts,  
 Fixture Suspension = 18", Desk Height = 2.5',  
 Whiteboard Dimension = 4' X 20', Whiteboard Location = Centered horizontally in the front of the room, 3' above the floor

\***Mode** refers to the four switching schemes with the CS/av system. See front page for details.

### 24' x 30' Classroom with 2-24' Fixture Rows

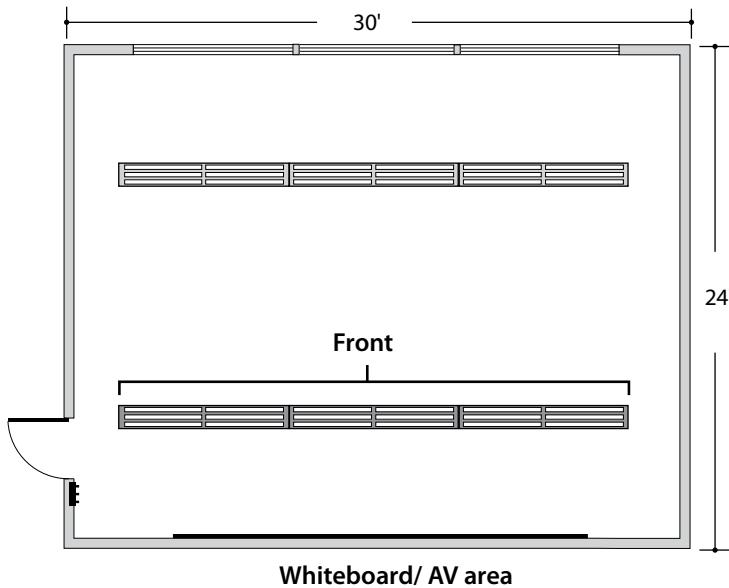

The diagram at left depicts a 24' X 30' classroom with two 24' rows of **SAE 7700** fixtures, which are parallel to the AV presentation/ whiteboard wall. Using the **CS/av** control solution, the fixtures in each of the rows can either have one or two lamps turned on depending on the lighting requirements of the students. The entire front row of fixtures is switched off in AV mode to minimize light in the projection area.

Mode*	# of lamps	Ave fc	Ave fc on Whiteboard	Ave/Min	Max/Min	W/ft <sup>2</sup>	LEED	CHPS
General	2	50	29	2.5	3.7	1.0	✓	✓
AV	1	12	3	7.0	20.9	0.3	✓	✓
All ON - Low	1	24	15	2.9	4.8	0.6	N/A	N/A
Front OFF - High	2	25	6	7.3	19.0	0.5	N/A	N/A

### 24' x 38' Classroom with 2-32' Fixture Rows

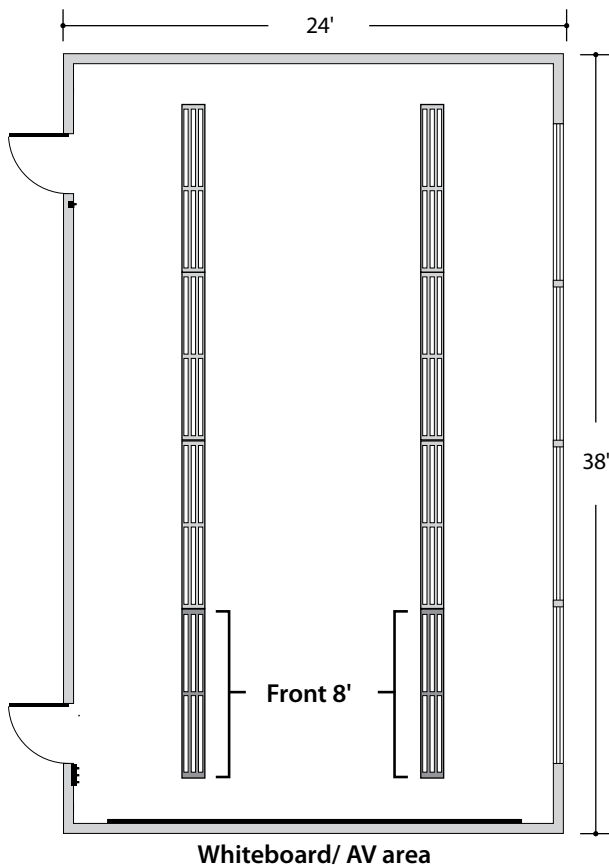

The diagram at left depicts a 24' X 38' classroom with two 32' rows of **SAE 7700** fixtures, which are perpendicular to the AV presentation/whiteboard wall. Using the **CS/av** control solution, the fixtures in each of the rows can either have one or two lamps turned on depending on the lighting requirements of the students. The front 8' of the fixtures in each of the rows are switched off in AV mode to minimize light in the projection area.

Mode*	# of lamps	Ave fc	Ave fc on Whiteboard	Ave/Min	Max/Min	W/ft <sup>2</sup>	LEED	CHPS
General	2	53	26	2.6	3.7	1.0	✓	✓
AV	1	19	4	8.7	17.8	0.5	✓	✓
All ON - Low	1	25	11	3.0	4.8	0.7	N/A	N/A
Front OFF - High	2	40	9	7.2	13.0	0.8	N/A	N/A



Litecontrol offers several choices for Control Solutions (CS) with the SAE 7700 fixtures used in classrooms. Whether the need is for a switching scheme to accommodate different teaching and AV modes, an easy-to-use daylight harvesting system, or a customized control solution that integrates a number of elements, our CS offerings provide design flexibility in meeting sustainability goals and energy code requirements.



The Litecontrol CS/av control solution provides flexibility for different teaching styles in the classroom, with an easy-to-understand switching scheme that was designed with the teacher and contractor in mind. Each CS/av system includes:

- Dual technology occupancy sensors to switch off the lighting when the room is vacant.
- Three wall switches: #1 serves as an overall on/off switch, and can be combined with additional entrance switches as needed; #2 provides a choice between high or low light level for general or AV lighting modes; and #3 provides a choice between having all the fixtures on for general lighting or switching off the fixtures in the front of the room for AV mode lighting.
- A custom-engraved face plate.
- A modular wiring box and modular wiring leads for easy connections between the power supply, occupancy sensor, switch boxes, and fixture rows.
- Fixtures pre-wired for two-circuit operation and front-to-back switching.



CS/dlh is a complete solution for daylight harvesting in classroom applications. The fixture-integrated WattStopper photosensor for active daylight harvesting works in conjunction with a 0-10 volt dimming ballast to provide continuous dimming based on available daylight levels. One sensor can control a full row of fixtures with up to 50 ballasts. Setup adjustments are easily made using the CS/dlh wireless remote. The CS/dlh solution helps designers satisfy CHPS daylighting criteria.



Litecontrol CS/e control solutions integrate Litecontrol fixtures with Lutron EcoSystem™ controls to offer design flexibility in specifying, purchasing and installing a comprehensive lighting solution. Fixtures are pre-wired for full compatibility with EcoSystem ballasts and controls. Sensors can be room- or fixture-mounted depending on the needs of the design.

## Other resources

([litecontrol.com](http://litecontrol.com) or contact your Litecontrol representative)

### Sustainable Lighting for Schools

color brochure on school lighting techniques and products

### SAE 7700 technical sheet

ordering and photometric data

### SAE 7700 IES datafiles

for use with lighting software

### CS/av technical sheet

ordering and typical applications for the AV control solution

### CS/av contractor guide

installation details for the AV control solution

### CS/dlh technical sheet

technical details for the daylight harvesting control solution

### CS/dlh contractor sheet

installation details for the daylight harvesting control solution

### Specifying CS/e

color brochure on CS/e control strategies and solutions

# LITECONTROL

employee owned | customer driven

100 Hawks Avenue Hanson, MA 02341  
781 294 0100 f: 781 293 2849 [litecontrol.com](http://litecontrol.com)

