

**INSTALLATION
INSTRUCTIONS**

FIXTURE TYPE _____

**P-S/I-0200
FIXTURE ASSEMBLY**

P/C 510533-2000

PG. 1 OF 2

DO NOT MODIFY OR ALTER THIS PRODUCT IN ANY WAY, OR INSTALL IN ANY FASHION WHICH IS CONTRARY TO THE INSTRUCTIONS CONTAINED HEREIN. IF YOU HAVE ANY QUESTIONS REGARDING THIS PRODUCT OR THE INSTALLATION OF IT, PLEASE CALL LITECONTROL ENGINEERING AT 781-294-0100.

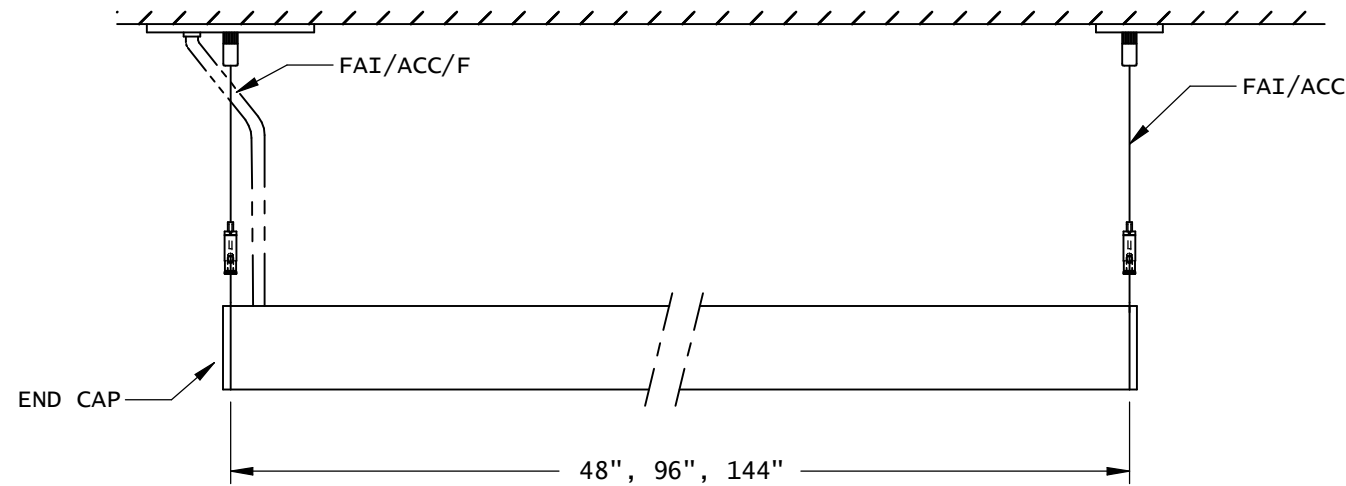

SIDE VIEW - INDIVIDUAL MOUNTED

GENERAL NOTES: (READ SHEETS COMPLETELY BEFORE STARTING)

1. Leave protective wrapping material on fixture until fixtures are mounted: This will protect finish from damage.
2. Fixtures are supplied with factory installed branch circuit wiring. Refer to supplemental instruction sheet for making connections.
3. Fixtures are hung with aircraft cables only. Cables are shipped separately. Refer to installation instructions for mounting to ceiling. Approximate weight of fixture is 2.0 lbs per foot of length.

INSTRUCTIONS:

1. MOUNTING INDIVIDUAL FIXTURES: (Pendants are shipped separately)

- A) Locate aircraft cables along a straight line in ceiling per dimensions shown in SIDE VIEW. (Refer to cable instruction sheet 510536).
- B) Peel back foam wrapping from both ends of fixture. Remove 5/8" dia knockout in socket plate for wire feed and remove Reflectors by removing sheet metal screws (See View C).
- C) Insert swaged balls on bow cable into keyholes on end headers at both ends of fixture as shown.
- D) Attach End Caps (shipped separately) to each end by inserting studs on End Cap thru holes in End Headers. Secure to fixture end with (2) #8-32 hex nuts. Before tightening nuts, position End Caps so they are flush with sides of housing. Note: End Cap with studs welded diagonally attach to left end of fixture (end without quick connects) See View "B". End cap with studs welded on same side attach to right end of fixture (end with quick connects) See View "A".
- E) Lift fixture and mount pendants to ceiling. Level fixture by adjusting gripper up or down on cable to position fixture in its final location. Level fixtures horizontally by loosening thumb screw in bottom of gripper and sliding gripper side to side on bow cable and re-tighten. Refer to cable instruction sheet 510536.
- F) Attach Strain Relief Bushing to Feed Cord and insert bushing into 5/8" ko. and make wiring connections.

GO TO STEP 4 ON PAGE 2.

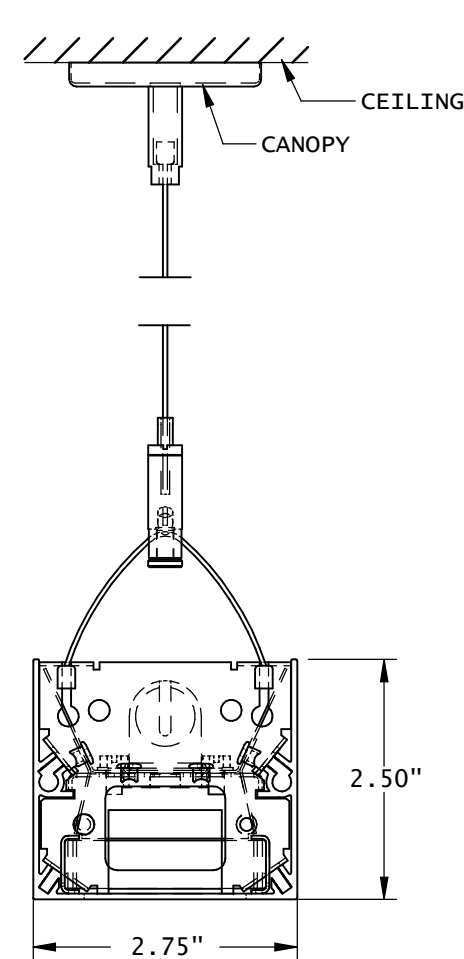

CROSS SECTION

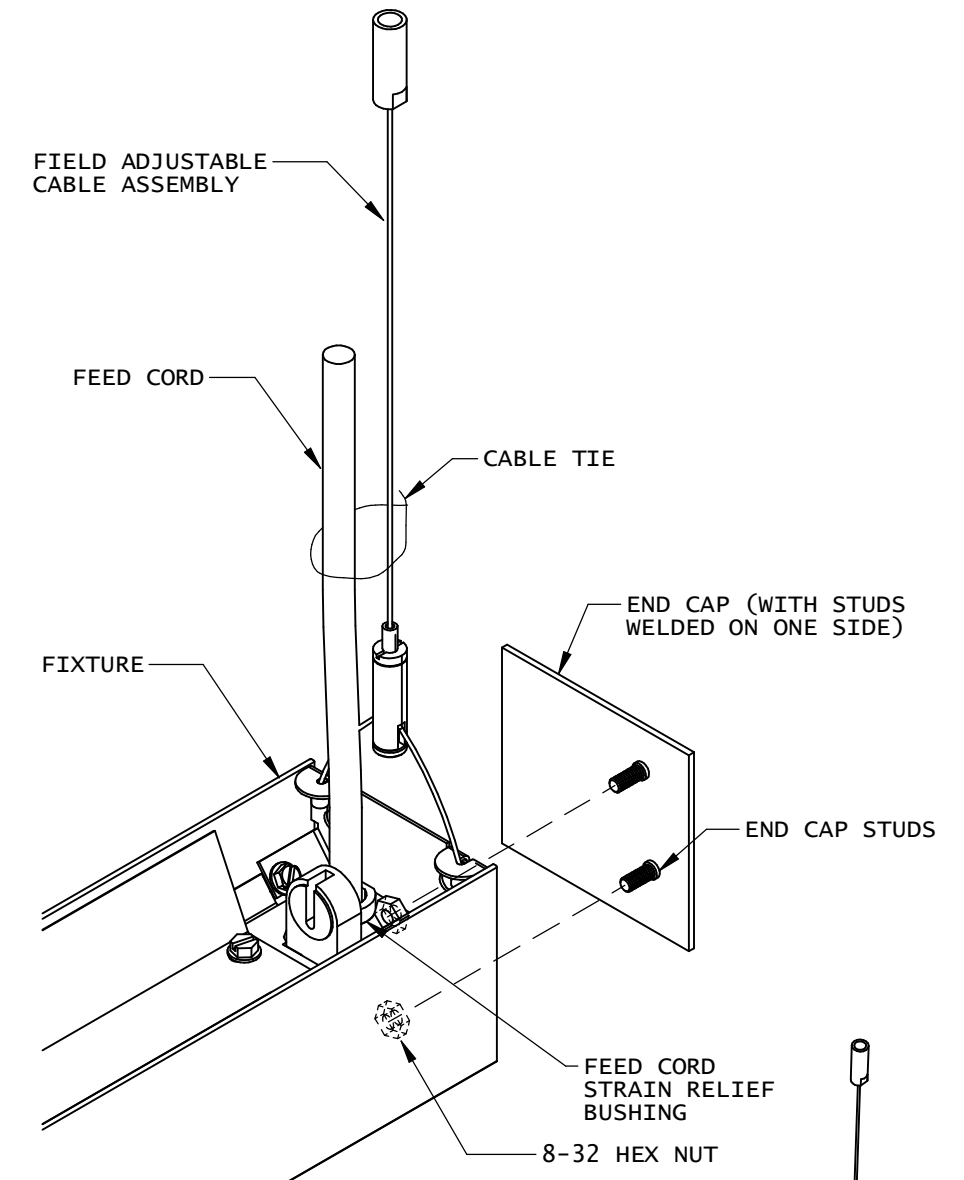

VIEW A

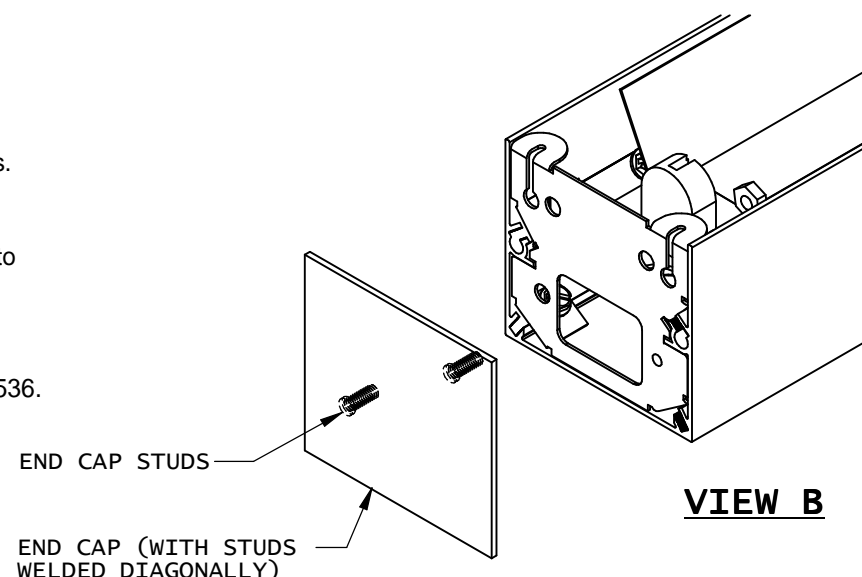

VIEW B

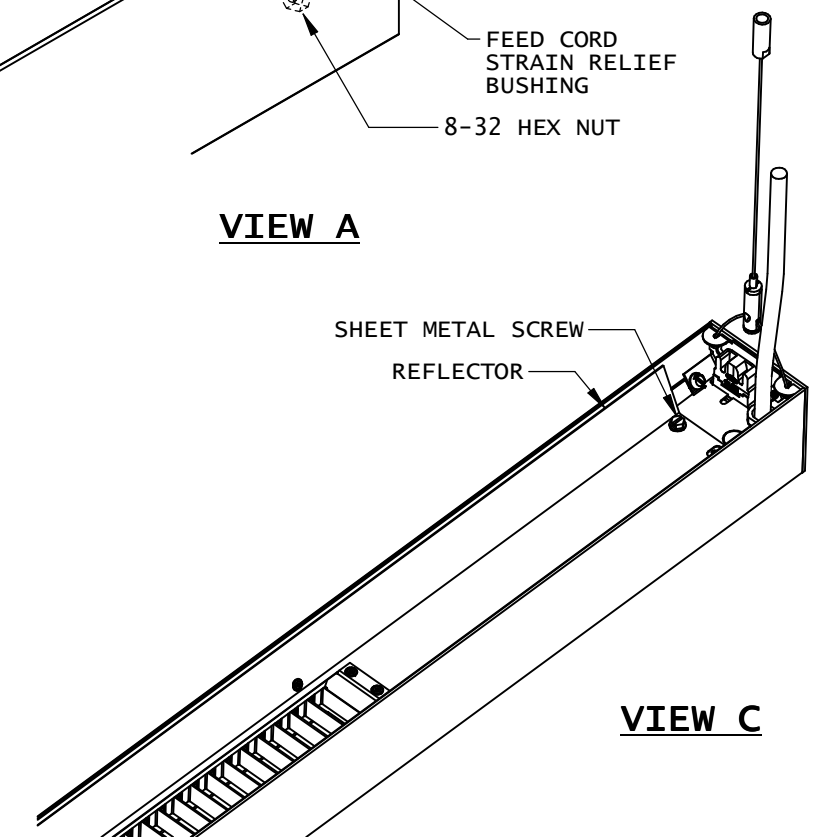

VIEW C

INSTALLATION
INSTRUCTIONS

FIXTURE TYPE _____

P-S/I-0200
FIXTURE ASSEMBLY

P/C 510533-2000

PG. 2 OF 2

DO NOT MODIFY OR ALTER THIS PRODUCT IN ANY WAY, OR INSTALL IN ANY FASHION WHICH IS CONTRARY TO THE INSTRUCTIONS CONTAINED HEREIN.
IF YOU HAVE ANY QUESTIONS REGARDING THIS PRODUCT OR THE INSTALLATION OF IT, PLEASE CALL LITECONTROL ENGINEERING AT 781-294-0100.

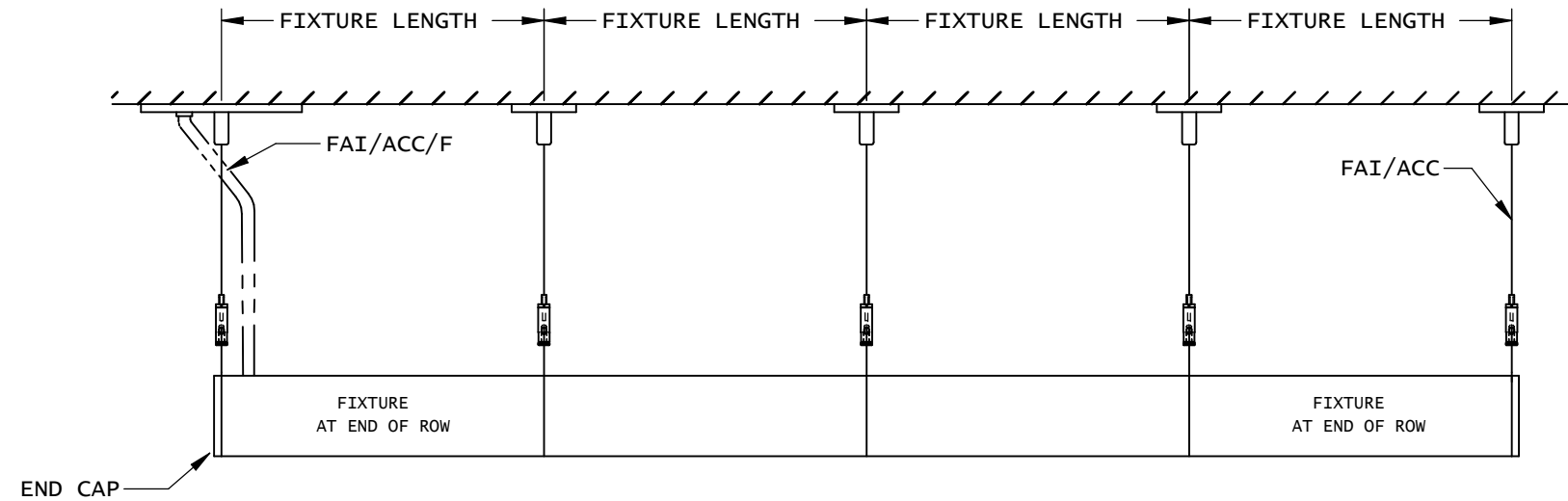

SIDE VIEW - ROW MOUNTED

INSTRUCTIONS con't:

2. MOUNTING ROWS OF FIXTURES:

- A) Locate aircraft cables in ceiling, along a straight line as shown in Side View. Refer to Cable Instruction sheet 510536.
- B) Starting with the fixture at one end of row, insert swaged balls on bow cable into keyholes in End Header as shown. Repeat at opposite end of fixture.
- C) Remove a 5/8" knockout in Socket Plate for wire feed.
- D) Attach End Cap to one end of fixture per step 1D on page 1. At opposite end of fixture insert dowel pins into fixture extrusion as shown.
- E) Lift fixture up and mount cable to ceiling. Refer to cable instruction sheet 510536.
- F) At the far end of the 2nd fixture in row, insert swaged balls on bow cable into keyholes in End Header.
- G) Lift this fixture up and attach cable to ceiling. At fixture joint, align dowel pins and insert into adjoining fixture. Secure fixture joint with 8-32 hex head machine screws and nut as shown in View "D".
- H) Level fixtures by adjusting gripper up or down on cable to position fixture in its final location. Level fixtures horizontally by loosening thumb screw in bottom of gripper and sliding gripper side to side on bow cable and re-tighten.
- J) Repeat steps F thru H for each additional fixture in row.

3. Wire feed may be brought into abutting fixtures thru wireway opening in End Headers. Make wiring connections.

4. Replace Reflectors. Clean fixture exteriors with a general window cleaner and install lamps (by others) by inserting lamp pins into sockets until they seat in place. For T5 lamps, insert lamp pins into socket and rotate lamp 90°.

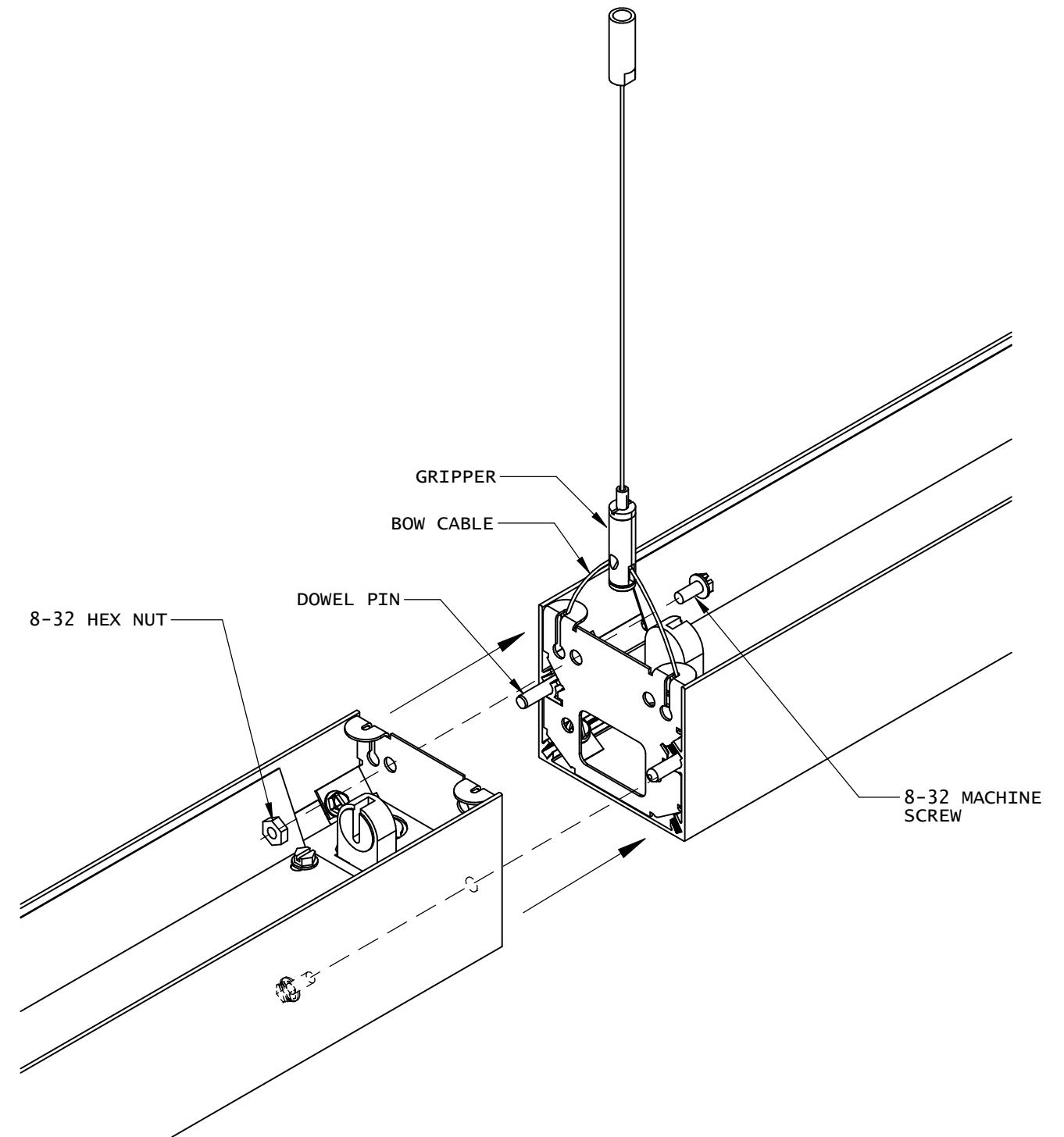

VIEW "D" - ROW JOINT ASSEMBLY