

INSTALLATION
INSTRUCTIONS

FIXTURE TYPE _____

FAI/ACC, FAI/ACC/F, FAI/ACC/V - FIELD
ADJUSTABLE CABLE ASSEMBLIES,
PD0200, PID82M/93M/82MS00, PSI0300
PG. 1 OF 2

P/C 510541-4000

DATE: 2-3-09

DO NOT MODIFY OR ALTER THIS PRODUCT IN ANY WAY, OR INSTALL IN ANY FASHION WHICH IS CONTRARY TO THE INSTRUCTIONS CONTAINED HEREIN.
IF YOU HAVE ANY QUESTIONS REGARDING THIS PRODUCT OR THE INSTALLATION OF IT, PLEASE CALL LITECONTROL ENGINEERING AT 781-294-0100.

GENERAL NOTES:

1. For all aircraft cable assemblies except FAI/ACC/F (cable assy w/feed) the contractor must securely install one 1/4-20 anchor stud or threaded rod at each cable location extending 3/4" below the ceiling line. Refer to fixture installation instructions for locations of cables.

The FAI/ACC/F cable assemblies are made to install over the following size *outlet boxes; (3-1/2" Octagon, 4" x 2-1/8" Handy Box, 3" x 2" Switchbox and Plaster Ring with 2-3/4" mounting hole locations).

WARNING: The National Electric Code requires that any fixture weighing more than 50 pounds be independently supported of an outlet box.

2. Fixtures in rows must be supported by a minimum of one cable at the junction of each two fixtures plus one at each end of the row, This is considered by "Underwriters Laboratories" as equivalent to two cables per fixture.

3. These cable assemblies are to be used only in conjunction with LITECONTROL products for which they were furnished. DO NOT use them for support of any other items or in any fashion which is contrary to this instruction sheet.

4. Cable assemblies are bulk packed and assembled as shown in View "A". They are provided in (3) lengths for ceiling to fixture heights of 6" - 48", 6" - 84" and 6" - 216".

* NOTE: Support Straps are also shipped with FAI/ACC/V assemblies for installation over non - feed outlet boxes.

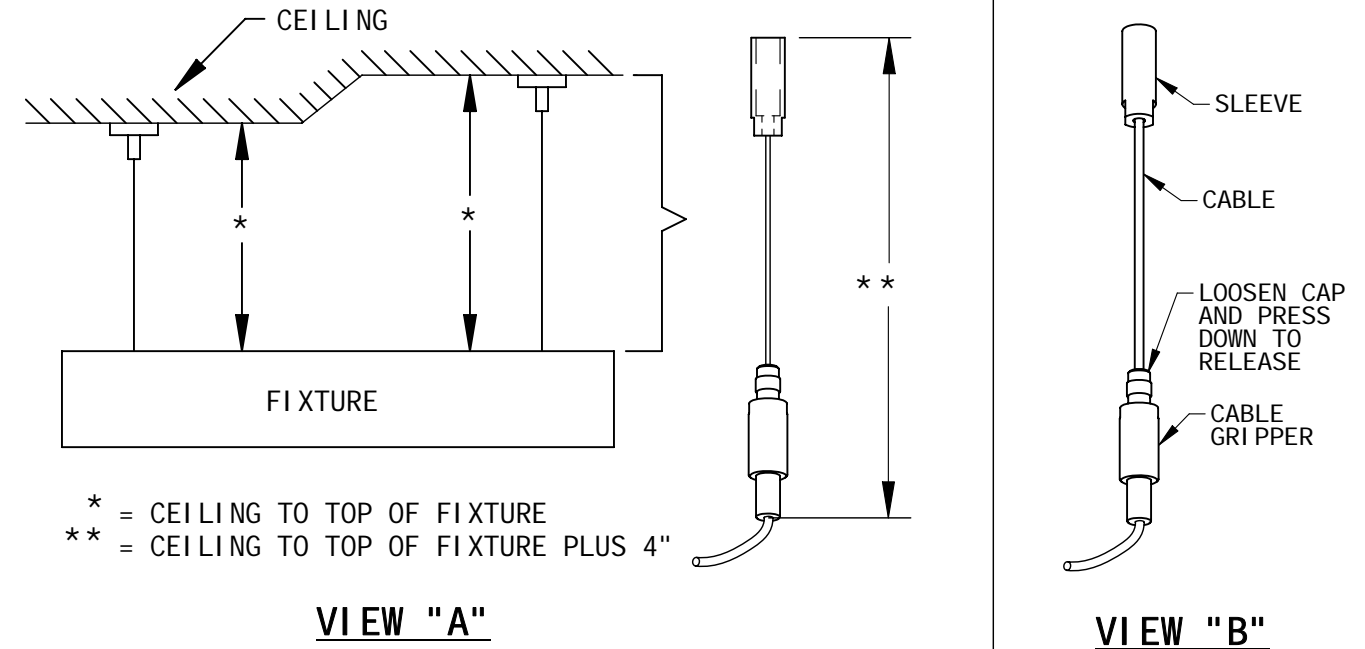
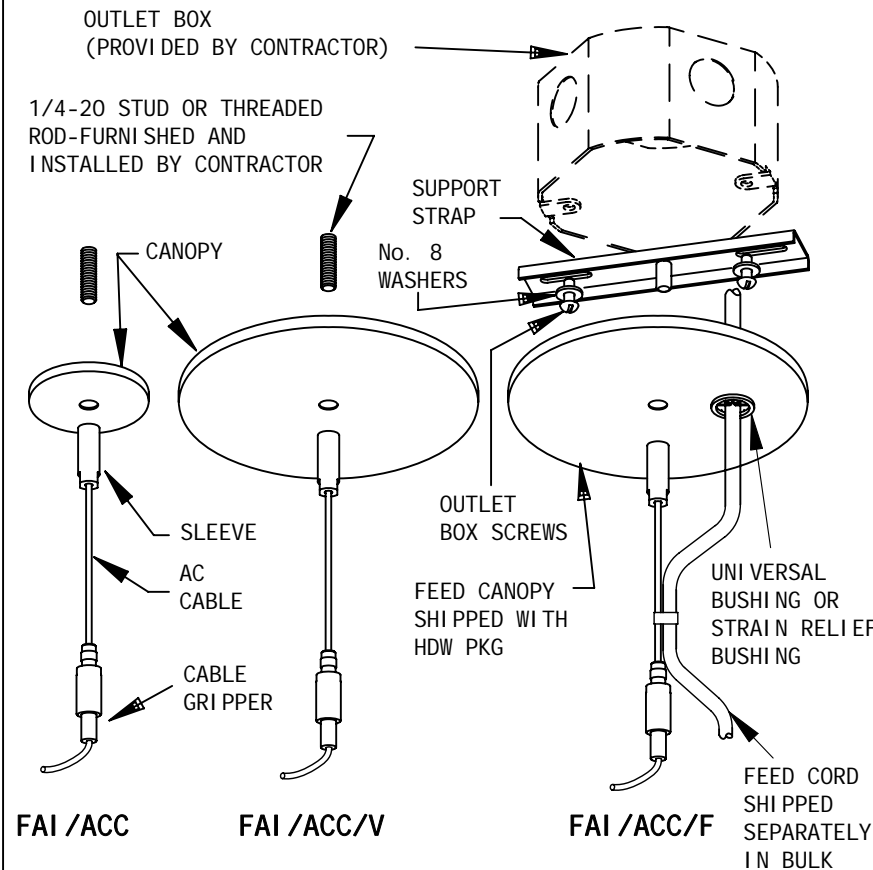

PREPARATION OF CABLE ASSEMBLIES:

Determine the distance from the ceiling to the top of the fixture and add 4" as shown in View "A". This is an approximate ceiling to top of fixture distance, final adjustment will be made after fixtures are hung. Slide Gripper to length **, by pressing downward on the spring loaded top as shown in View "B".

INSTALLATION OF AIRCRAFT CABLE ASSEMBLIES TO CEILING: Refer to View on the left.

For FAI/ACC and FAI/ACC/V cable assemblies: Place Canopy over ceiling stud or threaded rod and screw sleeve to stud.

For FAI/ACC/F cable assemblies: Mount outlet box flush with ceiling and attach Support Strap to box with outlet box screws and No. 8 Flat washers. Make electrical feed cord wiring connections in box and let cord hang down. Insert Universal bushing into hole in canopy and raise canopy up to Support Strap while leading the feed cord thru the bushing. Screw Cable Sleeve onto support strap stud, making sure that canopy is up against ceiling.

INSTALLATION
INSTRUCTIONS

FAI/ACC, FAI/ACC/F, FAI/ACC/V - FIELD
ADJUSTABLE CABLE ASSEMBLIES,
PD0200, PID82M/93M/82MS00, PSI0300
PG. 2 OF 2

P/C 510541-4000

FIXTURE TYPE _____
DATE: 2-3-09

DO NOT MODIFY OR ALTER THIS PRODUCT IN ANY WAY, OR INSTALL IN ANY FASHION WHICH IS CONTRARY TO THE INSTRUCTIONS CONTAINED HEREIN. IF YOU HAVE ANY QUESTIONS REGARDING THIS PRODUCT OR THE INSTALLATION OF IT, PLEASE CALL LITECONTROL ENGINEERING AT 781-294-0100.

MOUNTING AIRCRAFT CABLES TO PD-0200 FIXTURES: Refer to View "C":

Refer to fixture installation instruction sheet to prepare it for hanging.

- Mount Gripper thru the 5/16" holes in top of housing and into flat strap from inside of housing.
- While holding fixture up, press down on spring loaded top of gripper and pull cable thru side until fixture is level.
- Trim off excess cable.

MOUNTING AIRCRAFT CABLES TO PID-82M00, PID93M00 & PID82MS00 FIXTURES: Refer to View "D":

Refer to fixture installation instruction sheet to prepare it for hanging; Cable attachment is the same for these fixtures.

- Attach locknuts and washer to each Gripper and insert cable assembly thru cutout in back of End Header. Tighten top locknut against Support Bracket.
- While holding fixture up, press down on spring loaded top of gripper and pull cable thru side until fixture is level.
- Trim off excess cable.

MOUNTING AIRCRAFT CABLES AND FLAT STRAPS TO PSI-0300 FIXTURES: Refer to View "E":

Refer to fixture installation instruction sheet to prepare it for hanging;

Individual Fixtures: Attach a flat strap to the underside of the support angle at each end of fixture using (2) #8-32 x 3/8" hex head screw.

Row of Fixtures: A flat strap is attached underneath the fixture support angle at the end of the row where end cap is located. At row joint between two fixtures another flat strap is attached with (2) #8-32 hex head screws and positioned so that half of it protrudes out from end of fixture. Abutted fixture is lifted onto this strap and secured with #8-32 screws.

Lift fixture up to cable assemblies and thread grippers with 1/4-20 locknut into flat straps until tight against fixture support angle.

INSTALLING FEED CORD INTO FIXTURE: Catalog Designator "FAI/ACC/F"

NOTE: Feed Cord is shipped separately in bulk.

- Feed cord is mounted thru 5/8" holes or knockouts and is provide with both right angle and straight Strain Relief bushings. Use either bushing that suits your particular wire routing situation and discard the other.
- Make wiring connections inside fixture wireway in accordance with the NEC and any local codes.
- Use the nylon tie fasteners provided to secure feed cord to aircraft cable every 4" - 5". Snip off loose ends of fasteners.

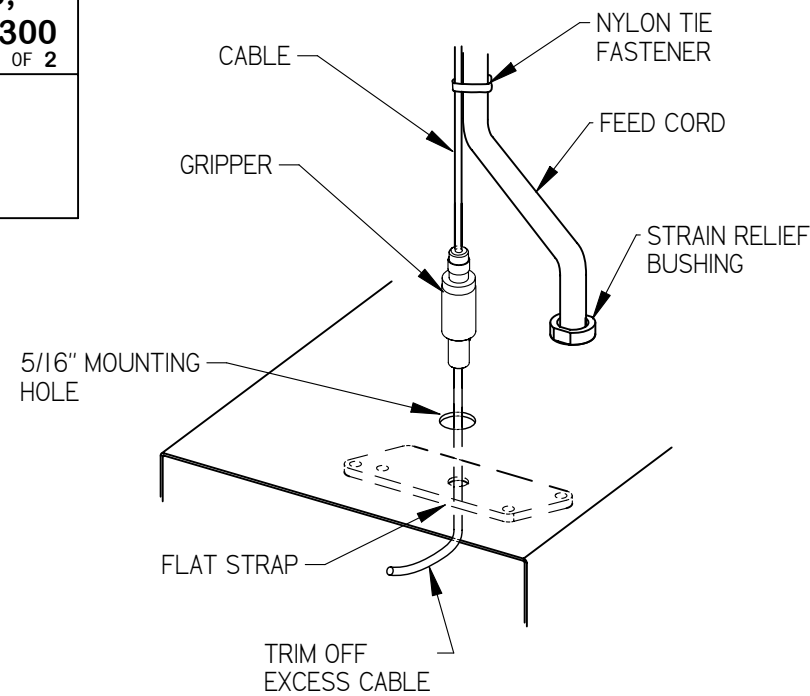

VIEW "C"
PD-0200 FIXTURES

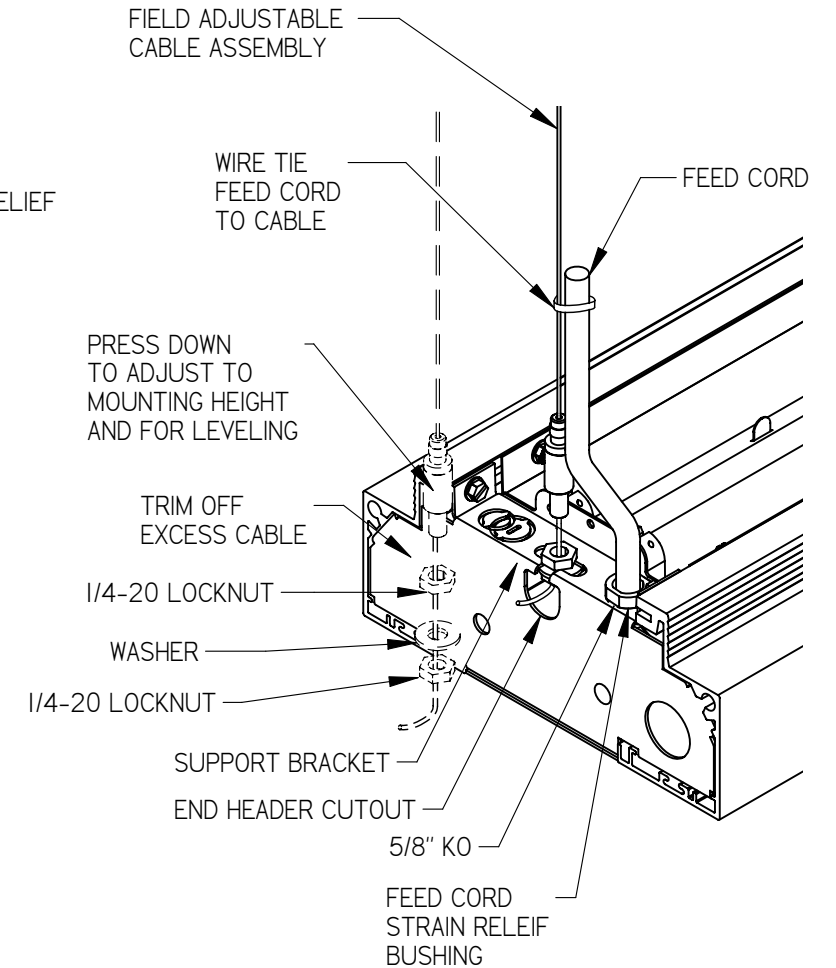

VIEW "D"
PID82MS00 FIXTURE SHOWN

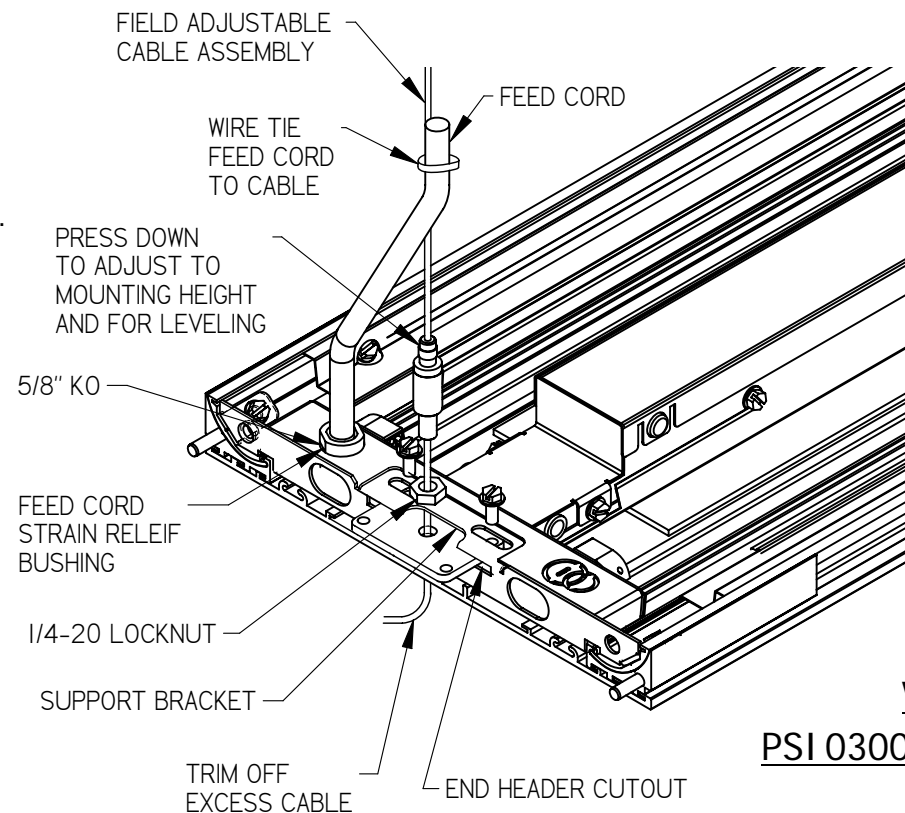

VIEW "E"
PSI0300 FIXTURE SHOWN